

BUCKET ELEVATOR TYPE E11



Bucket elevator type E11 is built in standard elements and can easily be fitted into industrial plants and feed mills.

JEMA AGRO bucket elevator is made of galvanized steel and designed for industrial use and thus a very large number of operating hours. The bucket elevator is designed for the transport of bulk goods, meal feed, grains and granules. E11 elevator can optionally be fed in either up going side or down going side. The capacity is the same.

Standard equipment:

- Foot geared motor with back stop
- Wear plate in elevator head
- Removable elevator top
- Tightening function in elevator boot
- Cleaning hatch in elevator boot
- Elevator feet
- Inlet piece 45°
- Elevator extension with inspection cover
- Speed control monitor
- Antistatic belt with plastic elevator buckets

Accessories:

- Transition pieces and pipe
- Extra inlet
- Inlet shutter
- Inlet 45° for inlet shutter
- Aspiration socket
- Misalignment sensor
- Extra feet
- Inlet for auger
- Service platform, ladder, and resting platform

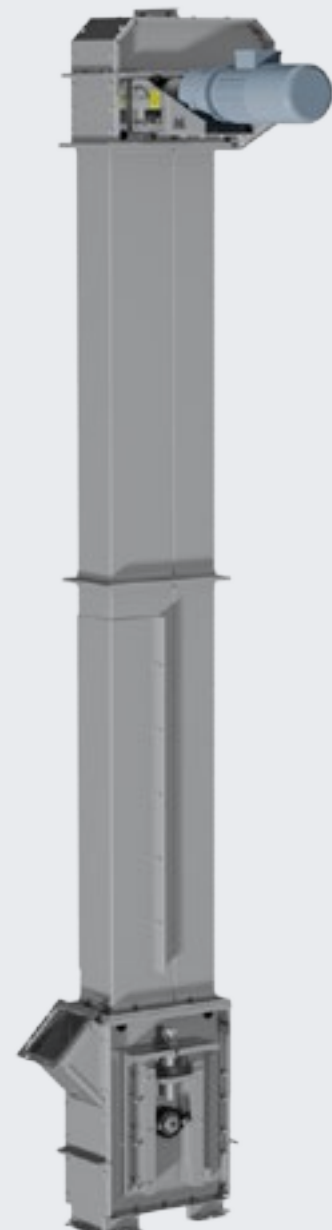

BUCKET ELEVATOR TYPE E11



Dimensions E11 Bucket elevator:

	A	B	C	D	E
E11	510	305	300	125x125	278

	F	G	H	I	J
E11	135	450	420	40	125x125

	K	L	M	N	O
E11	460	335	705	215	340

Technical specifications:

	E11
Capacity based on 750 kg/m ³ (wheat) t/h	5,25 t/h
Capacity m ³ /h	7 m ³ /h
Rotation speed	415 RPM
Belt speed	2,17 m/s
Drum diameter	Ø100 mm
Bucket/m. belt	10 pcs
Bucket volume, horizontal/max	0,06/0,16 Liters
Material thickness, buckets	1,0 mm
Belt width	100 mm
Belt type	EP400/3
Plate thickness, head	2/3 mm
Plate thickness, boot	2/3 mm
Plate thickness, extension	1,5 mm
Max height	10 m

