

BELT CONVEYOR

TYPE T50 / T51 / T52



Belt conveyor type T50/T51/T52 is made up of standard elements which, when correctly combined, can easily be fitted into any conveying installation.

The JEMA AGRO belt conveyor is manufactured in galvanised steel and designed in a light and easy-to-assemble modular system. All 3 types are constructed with rollers. They have a low noise level, and have in relation to their capacity a low power consumption.

The belt conveyor can transport materials in both directions. There is also a possibility for transport at an upward angle of up to 30° using carriers, however, with reduced capacity. The belt conveyor is designed for industrial purpose, and it is suitable for gentle transport of most materials.

Standard equipment:

- Directly mounted gear motor
- Torque arm for shock absorption
- EP-belt
- Support rollers each 0,5 m
- Returning rollers each 2,0 m
- Shielding for drive station /tightening section
- Tightening in both drive station and tightening section

Accessories:

- Inlet hoppers
- Outlet skirts/outlet hoppers
- Cover for top/bottom
- Speed control monitor
- Moveable tripper carriage
- Drive winch for tripper carriage
- Belt with vulcanised v-carriers
- Runners for adjustable support fittings
- Belt guide rollers
- Belt scraper internal
- Belt scraper external
- Side extensions
- Oil resistant belt
- Outlet deviser



BELT CONVEYOR

TYPE T50 / T51 / T52

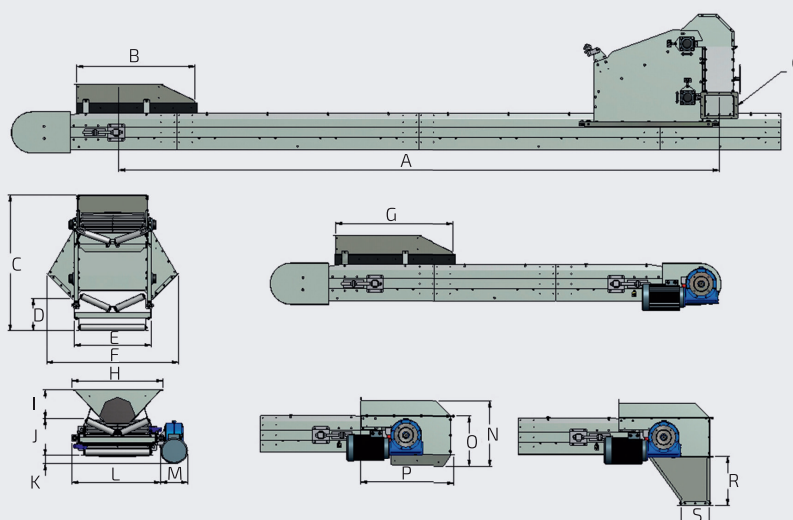

Dimensions T50/T51/T52:

	A	B	C	D	E	F	G	H	I
T50	Min. 5000	1000	955	320	535	1000	1000	650	215
T51	Min. 5000	1000	1150	300	635	1100	1000	750	215
T52	Min. 5000	1150	1225	300	785	1330	1150	900	215

	J	K	L	M	N	O	P	Q	R	S
T50	300	70	650	200	540	415	780	240 x 240	400	240 x 240
T51	300	70	750	200	540	415	780	240 x 240	400	240 x 240
T52	300	70	900	200	540	415	780	300 x 300	400	300 x 300

Technical specifications:

	T50	T51	T52
Capacity based on 750 kg/m ³ (wheat) t/h	60 t/h	105 t/h	150 t/h
Capacity m ³ /h	80 m ³ /h	140 m ³ /h	200 m ³ /h
Rotation speed	150 RPM	150 RPM	150 RPM
Belt speed	2,3 m/s	2,3 m/s	2,3 m/s
Drum diameter	Ø300 mm	Ø300 mm	Ø300 mm
Belt width	400 mm	500 mm	650 mm
Belt type	EP250/2	EP250/2	EP250/2
Plate thickness, drive station/ tightening section	2/3 mm	2/3 mm	2/3 mm
Plate thickness, extension	2/3 mm	2/3 mm	2/3 mm

